

Water Separator (SAMG)

SAMG150~850 Series



150-550 series can be combined with other modular equipment.

- SAMG series filter aims at eliminating waterdrops.
- SAMG series eliminate waterdrops up to 99% at the area of inlet of pneumatic machinery equipment and at the last stage of using air in the workroom.
- SAMG series are effective to the place such as
 1. which does not have to be dry as much as air drier.
 2. which is not able to install air drier for its restriction.

How to order

SAMG 350 - 03 BD - MeP - S

① Water Separator

② Body Size

- 150 - 1/8
- 250 - 1/4
- 350 - 1/2
- 450 - 3/4
- 550 - 1
- 650 - 1 1/2
- 850 - 2

③ Thread type

- Nil - Rc(PT)
- N - NPT
- G - G(PF)

④ Port Size

Symbol	Size	Body size						
		150	250	350	450	550	650	850
01	1/8	●						
02	1/4	●	●					
03	3/8		●	●				
04	1/2			●				
06	3/4				●	●		
10	1					●		
12	1 1/4						●	
14	1 1/2						●	●
20	2							●

⑤ Accessory(Optional)

- Nil - None Bracket / Manual Drain
- B - Bracket
- D - Auto Drain

Symbol	Drain connector	Material
D	One-touch fitting(Φ6mm)	Acetal
Dn	Nipple(PT 1/8)	Brass

⑥ Bowl

- Nil - Metal bowl with flat type sight glass(MeF)
- PcS - Polycarbonate bowl with Steel guard
- MeP - Metal bowl with pipe type sight glass
Note) 150 and 250 are the integral cover and bowl(MeF type).

⑦ Option

- Nil - None
- S - Differential Pressure Indicator

Symbol

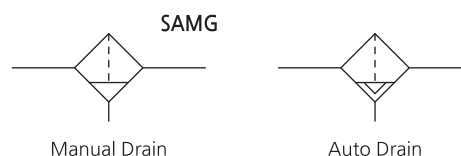

Specification

Fluid	Compressed Air
Max. operating pressure	10bar (1.0MPa)
Min. operating pressure	1.5bar (0.15MPa)
Max. supply pressure	15bar (1.5MPa)
Ambient and Media temp.	5~60℃
Removal rate of water	99%
Life of element	When pressure drop reached at 1bar

Precautions

- ① Water separator can remove water droplets, but it cannot remove moisture.
- ② Filter element should be changed after 2years of use or when pressure drop reached at 1bar(0.1MPa).
- ③ When auto drain is used, drain piping should be both 4mm or greater in diameter and less than 1m in length. Avoid installing drain piping upwards.
- ④ When auto drain is used it is recommended to use at least 1.5bar pressure.
- ⑤ When auto drain is inoperable, drain manually by pushing the one-touch fitting upward.
- ⑥ Before disassembling the equipment on the compressed air side to inspect the auto drain or to replace the filter element, confirm that the pressure is set to zero.

FLOW CHARACTERISTICS

Note : If compressed air is above max. flow, water separator cannot operate well.

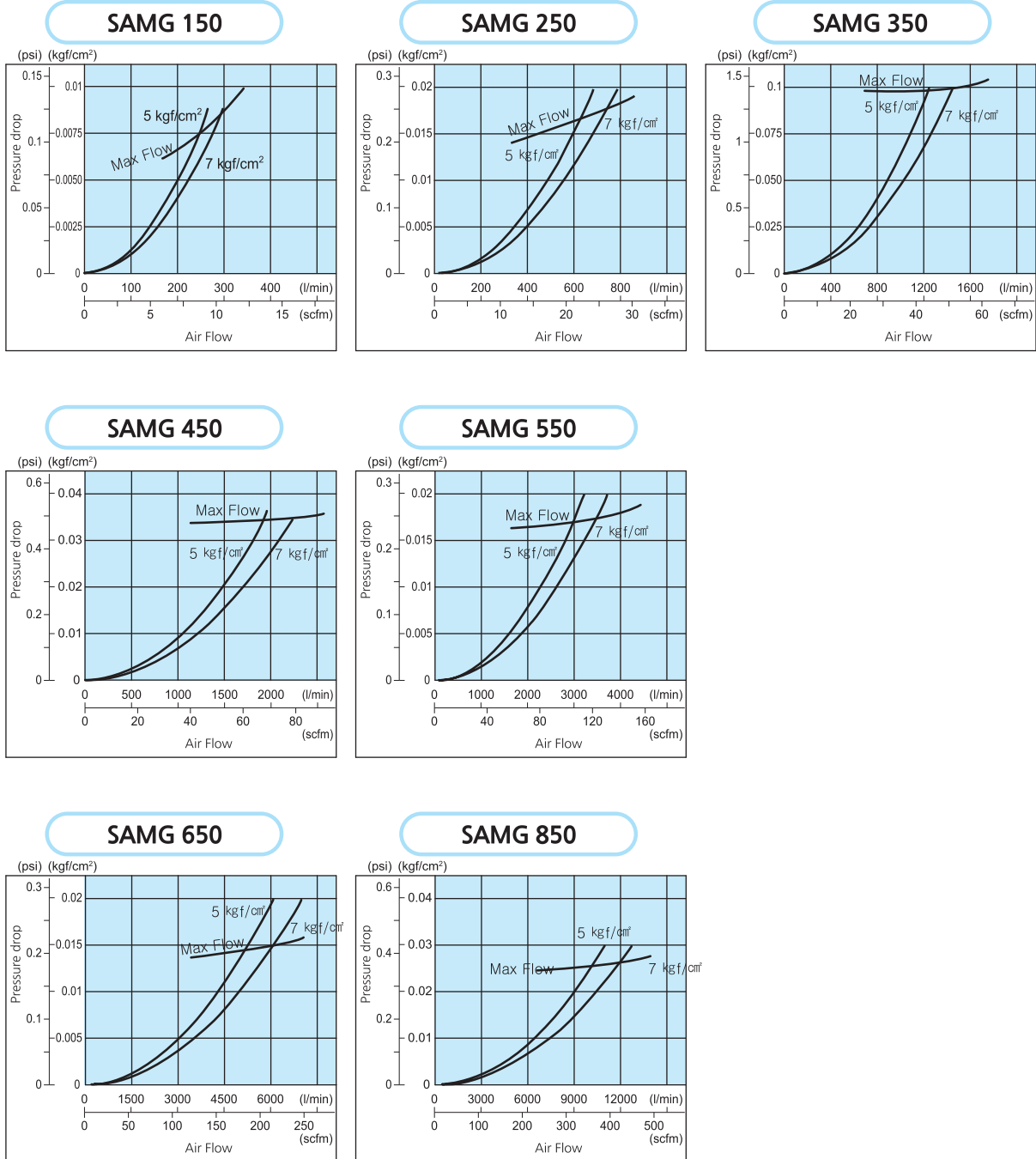

STRUCTURE / PARTS

SAMG 150~250

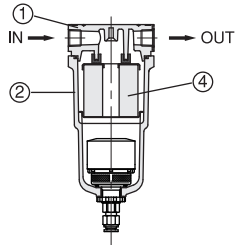

SAMG 350~550

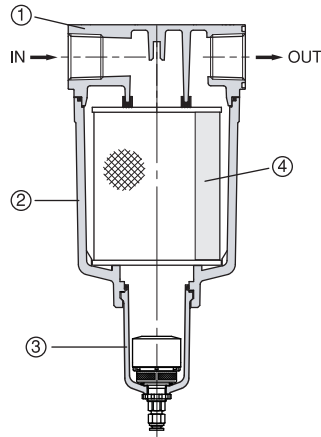

SAMG 650~850

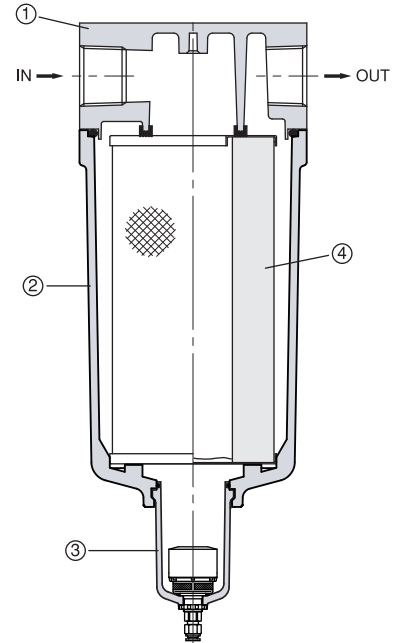

Component Parts

No.	PARTS	MATERIAL
①	Body	ALDC
②	Housing	ALDC
③	Bowl Ass'y	ALDC(MeP type)
		ALDC(MeF type)

Replacement Parts

(mm)

No.	PARTS	Part No. & Size(Φ x Height)						
		AMG-EL150	AMG-EL250	AMG-EL350	AMG-EL450	AMG-EL550	AMG-EL650	AMG-EL850
④	Filter	45 x 42	58 x 52.5	70 x 77	82 x 87	95 x 117	122 x 144	130 x 260

Sectional drawing (SAMG Filter)

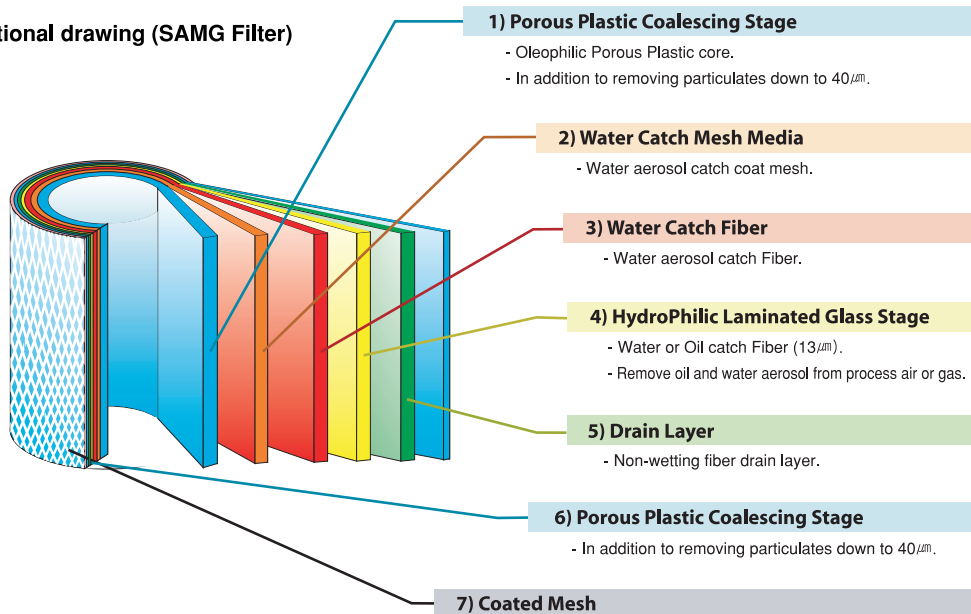

Series SAMG

DIMENSIONS (mm)

SAMG 150~550

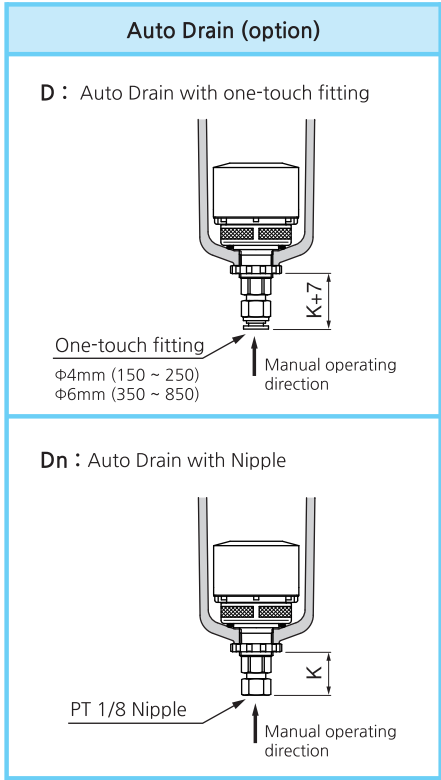
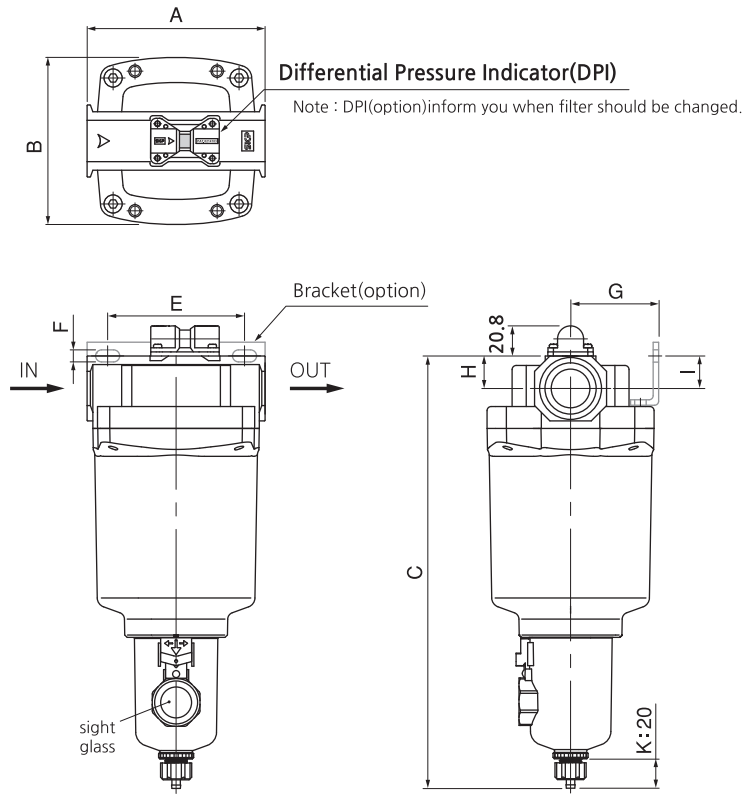

- **MeP** - Metal Bowl with pipe type sight glass

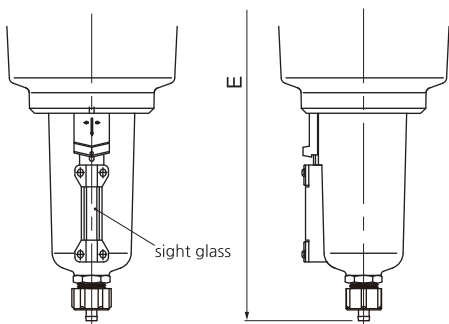

Note : 150 and 250 are the integral cover and bowl(MeF type)

Model	Port size	A	B	Height(manual drain)		E	F	G	H	I
				C(MeF)	D(MeP)					
SAMG 150	1/8, 1/4	67	66	158.5	-	56	6	33.6	10.5	19.7
SAMG 250	1/4, 3/8	82	76	177.7	-	66	6	39.5	14	13.5
SAMG 350	3/8, 1/2	98	90	253	273	80	7	49.8	17.9	15.9
SAMG 450	3/4	114	106	271.3	291.3	90	9	56.2	19.8	15.3
SAMG 550	3/4, 1	130	122	311.2	331.2	100	8.8	64.5	23.7	21

DIMENSIONS (mm)

SAMG 650~850

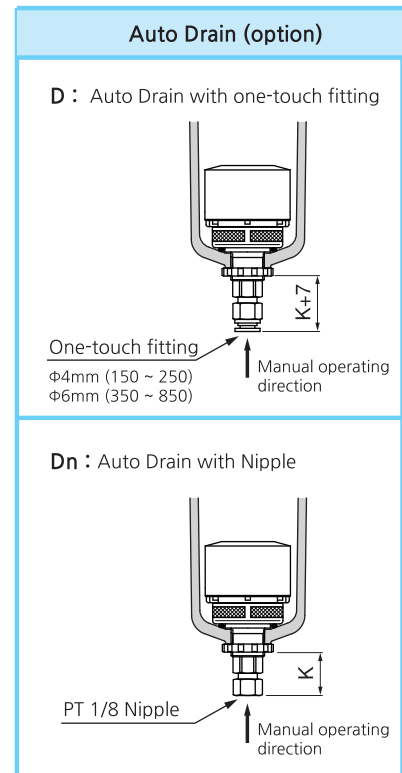
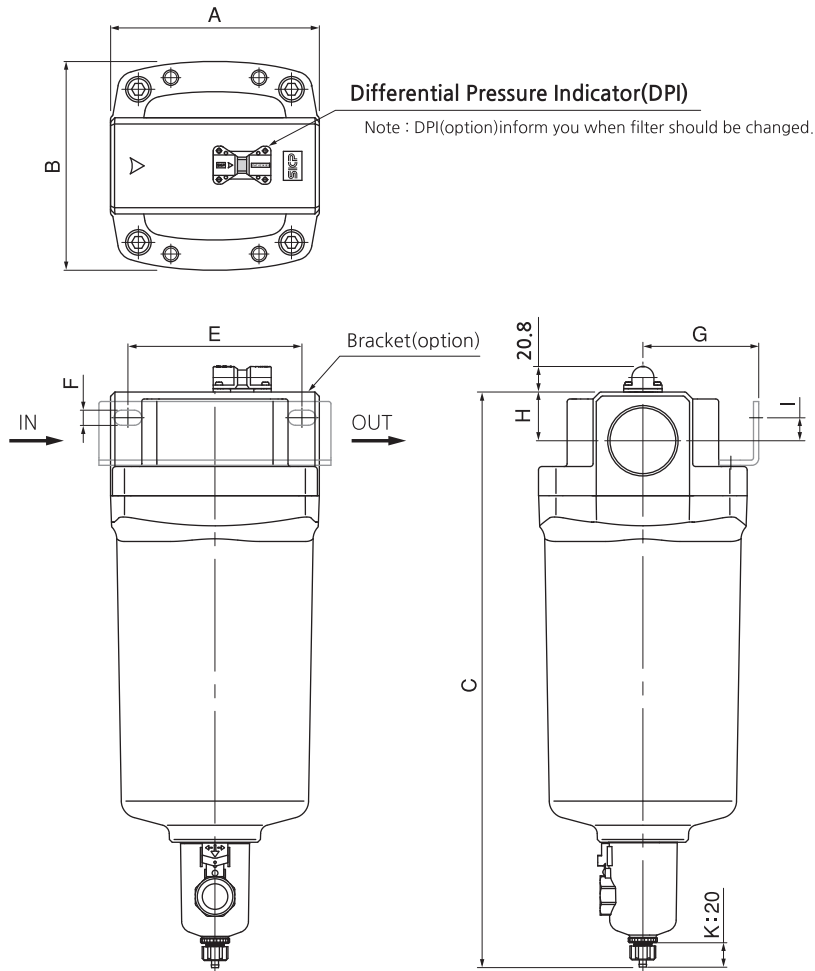

- MeP - Metal Bowl with pipe type sight glass

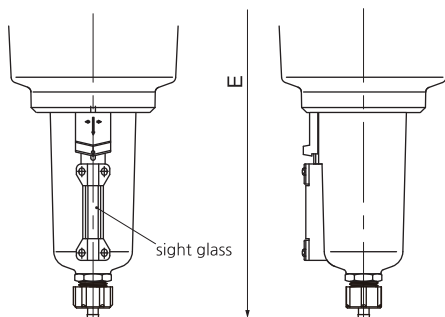

Model	Port size	A	B	Height(manual drain)		E	F	G	H	I
				C(MeF)	D(MeP)					
SAMG 650	1 1/4, 1 1/2	160	160	361.2	381.2	150	13	93	32	27
SAMG 850	1 1/2, 2	180	180	490.7	510.7	150	13	100	42	20